

MC1000 and MC2000 — Motion Compensated Standards Converters



Technical Data Sheet

MC1000 and MC2000 are cost effective motion compensated standards converters.



MC100 and MC2000 Applications

- International Program Distribution
- Content repurposing for internet, TV and Blu-ray distribution
- International TV and video production

Features

- Motion compensated SD/HD/3G frame rate conversion
- SD/HD/3G up, down and cross conversion
- Independent dual channel conversion (MC2000 only)
- Flexible video and audio i/o configuration

- 16-channel embedded audio processing for each video channel
- Continuous output when input standard switches
- HDMI monitor output
- Dual PSU as standard
- Relay bypass on primary SDI inputs
- Automatic Aspect Ratio Conversion (AFD, VI, L23)
- Powerful picture enhancement tools
- Front panel and remote control via web interface and RollCall
- Closed caption and timecode handling
- Synchronization
- User chosen line for SMPTE 2016

- GPI support
- Front panel control lock
- SMPTE2020 metadata support
- Dolby delay compensation
- Caption generator
- Logo inserter
- Sidebar keyer
- Clean cut

Optional Features

- Composite input / output
- One (MC1000) or two channels (MC2000) of Dolby®E decode/encode
- Fiber input / output

MC1000 Video Processing

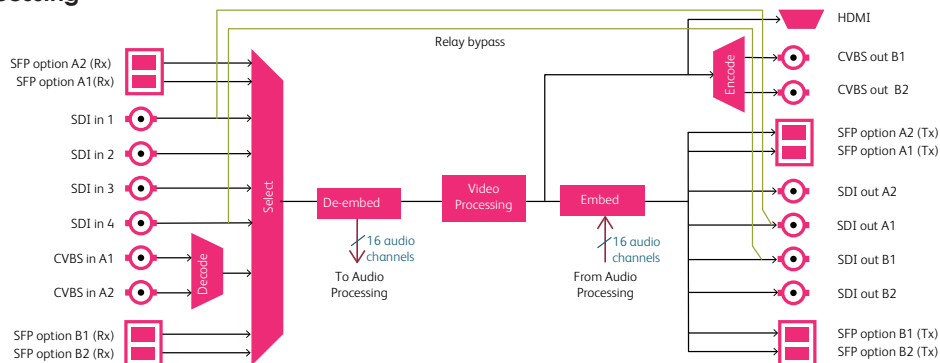

MC1000 Audio Processing

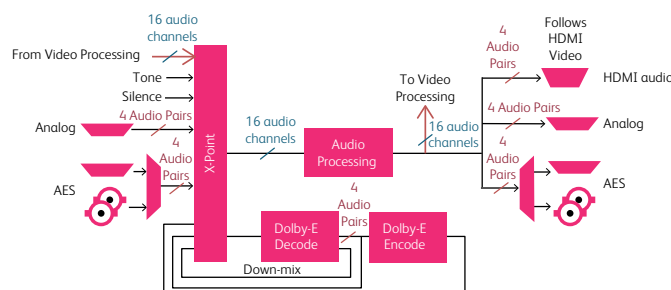

MC2000 Video Processing

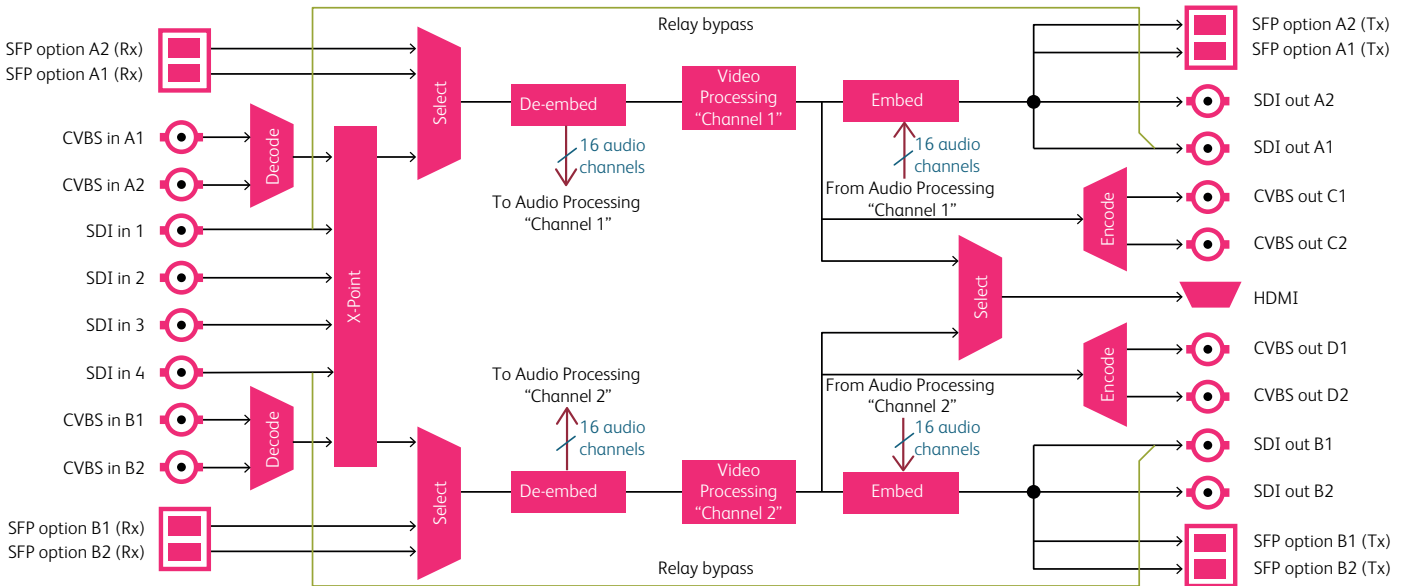

MC2000 Audio Processing

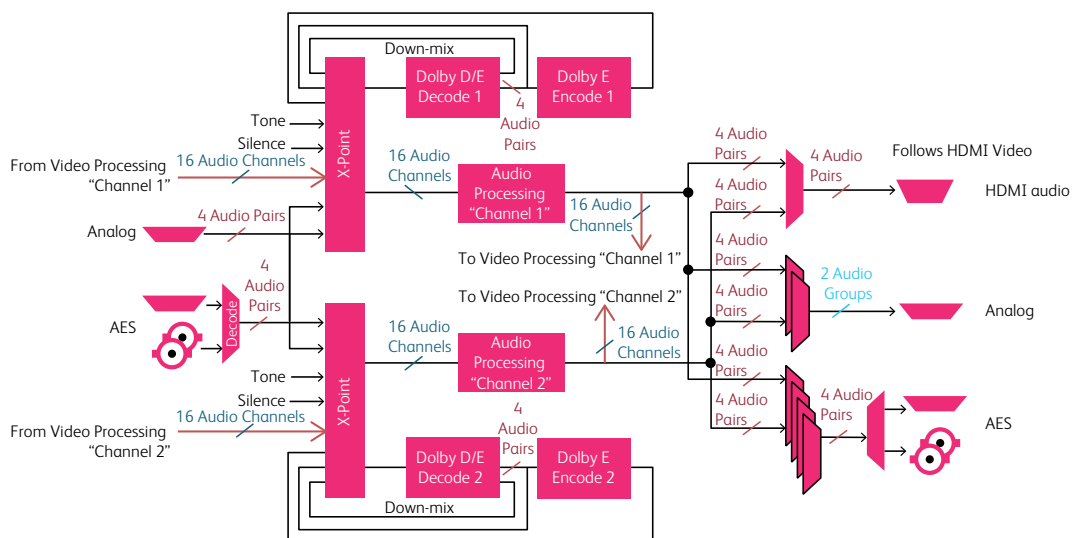

Technical Specification

Signal Inputs

Serial digital 4 x 75 Ohm SD/HD/3Gb/s serial digital with embedded audio
Input standards: 3Gb/s SD-SDI, SMPTE425 level A, level B
1.5 Gbit/s HD-SDI SMPTE292M/SMPTE299M
270 Mbit/s SD-SDI SMPTE259M
Composite PAL, NTSC, NTSC-J, PAL-M, PAL-N, N4.4, SECAM
12-bit ADCs
Analog component YC

Reference 1 x loop-through HDTV Trisync/SD Bi-sync (black & burst) SMPTE 240M/274M

Audio AES 4 x Balanced AES inputs – via 25 way D Type
4 x Un-balanced AES inputs – via 4 x BNC
Audio analog 4 x Stereo Analog inputs via 25 way D Type

Signal Outputs

Serial digital 4 x 75 Ohm SD/HD/3Gb/s serial digital with embedded audio
Output standards: 3Gb/s HD-SDI, SMPTE425 level A, level B
1.5 Gbit/s HD-SDI SMPTE292M/SMPTE299M
270 Mbit/s SD-SDI SMPTE259M
Composite PAL, NTSC, NTSC-J, PAL-M, PAL-N, 12-bit DACs
Analog component YC

Audio AES 4 x Balanced AES outputs – via 25 way D Type
4 x Un-balanced AES outputs – via 4 x BNC
Audio analog 2 x Stereo Analog outputs via 25 way D Type

Input standard

Input standard
(auto detect) 525, 625
720 50/59.94/60p
1080 50/59.94/60i
1080 50/59.94/60p (Levels A and B)
720/1080 23/24/25/29/30p
1080 23/24/25/29psf

Output standard

525, 625
720 50/59.94/60p
1080 50/59.94/60i
1080 50/59.94/60p (Levels A and B)
720/1080 23/24/25/29/30p
1080 23/24/25/29psf

Conversion Functions

Modes SD/HD/3Gb/s Motion Compensated Standards Conversion
Standards Conversion
Up Conversion, Down Conversion, Cross Conversion
Conversion Linear / motion compensated

Conversion processing

Still process: Detects still images and applies an aperture with full (progressive) vertical frequency response.
Enhanced still: Adds field motion detection to still process. Prevents artifacts on moving repetitive patterns.

Manual or Automatic ARC

AFD (SMPTE 2016), VI (RP186), WSS (L23)
SD input format Normal 4:3, Anamorphic 16:9, Letterbox 14:9, Letterbox 16:9
SD output format Normal 4:3, Anamorphic 16:9, Letterbox 14:9, Letterbox 16:9
Auto zoom On/Off
Manual zoom Zoom +/- 20%
Safe area marker Off, 16:9, 4:3
Manual controls : size, aspect, pan, tilt
Wide range of ARC presets including 702 sample line mode

Audio Functions

Analog Audio

- Four pairs of analogue inputs are individually available to any or all processing channels
- Two groups (2 pairs) of analogue output are separately assignable to any processing channel
- Headroom +24dBu; balanced connection

AES Audio

- Four AES audio inputs are individually available to any or all processing channels
- Four AES audio outputs (48kHz) are separately assignable to any processing channel
- AES input is auto-detected as PCM (32-96kHz) or non-PCM (48kHz locked to relevant video input)

Embedded Audio

- Each processing channel includes 16-channel embedded audio processing
- PCM audio processing includes channel level gain and delay compensation, as well as channel level routing/shuffle with audio phase inversion
- Non-PCM processing features pair level routing and delay compensation.
- Dolby-E data is passed with a delay to match the video and with co-timed audio frame drop or repeat.

Dolby[®]E

- Optional single channel Dolby[®]E passing in convert mode on MC1000
- MC2000 has option of single channel Dolby[®]E passing on both processing channels

Metadata

Closed caption CEA608 <> CEA708
Timecode conversions
WST/RDD8 conversion
SMPTE2020 embed/de-embed

Enhancement

Advanced Horizontal Enhancement
Frequency band selection (Low, Med, High)
4 preset enhancement levels (Soft 2, Soft 1, Normal, Sharp 1, Sharp 2)
Custom H Gain and H Noise rejection levels.

Advanced Vertical Enhancement

Frequency band selection (Low, Med, High)
5 preset enhancement levels (Soft, Normal, Sharp 1, Sharp 2, Sharp 3)

Horizontal Aperture

5 preset H sharpness levels (Low 2, Low 1, Normal, High 1, High 2) 5 preset H detail levels (Soft 2, Soft 1, Normal, Sharp 1, Sharp 2)

Noise reduction : spatial, recursive

Y/C alignment : corrects for up-stream luma chroma displacement

System

Pattern Off , Black, Ramp, Bars
Proc amp
Black Level +100 to -100mV (0) in 0.8mV steps
Contrast -6dB to +6dB (0) in 0.2dB steps
Saturation -6dB to +6dB (0) in 0.2dB steps
Y Gamma 0.4 to 1.7 (1) in 0.1 steps
Freeze On/Off
Genlock Reference lock, Input lock (same format), Follow input (same frame rate), Free run
Memories 16 user memories
Legalizer
EDH support

Remote control via web interface and RollCall network (IP)

Power (Primary and Secondary)
Input voltage range 100 – 240 VAC, 50/60 Hz 1.5A (Max) via three pin IEC power socket"

Temperature range 0 to 45° C operating
Cooling Internal Fan, side venting
Weight Approximately 4.25kg
Case type 1RU, Rack Mounting
Dimensions 44mm x 430mm x 400mm (h,w, d)
Headphones socket with volume control.
GPIO : 8 available

Throughput delay

Video processing delay
field = 16.7 or 20ms
frame = 33.3 or 40ms

With scaling active in same frame rate:

Ref lock / Free run - Between 3 and 5 fields + ~200us;
Input lock(SDI) – 3 fields + 1ms

With same standard in & out and Sync mode = Enabled:

Ref lock / Free run - Between ~200us and 1 frame + ~200us;
Input lock(SDI) – ~1ms

Frame rate conversion:

Any lock mode – 110ms typical

Communications

Mechanical

Throughput delay

Audio processing delay
(Audio delay = 0ms)

With scaling active in same frame rate:

Ref lock / Free run – 1.5 frames;
Input lock – 1 frame + 1ms

With same standard in & out and Sync mode = Enabled:

Ref lock / Free run – 0.5 frames;
Input lock – ~3ms

Frame rate conversion:

Any lock mode – 110ms typical



(Note rear panel shows MC2000 with CVBS option fitted)