

PANORAMAdtv, the video division of Wohler Technologies, Inc.

PANORAMAdtv VAMP2-SDA

SDI Video & Audio Monitoring in 2U

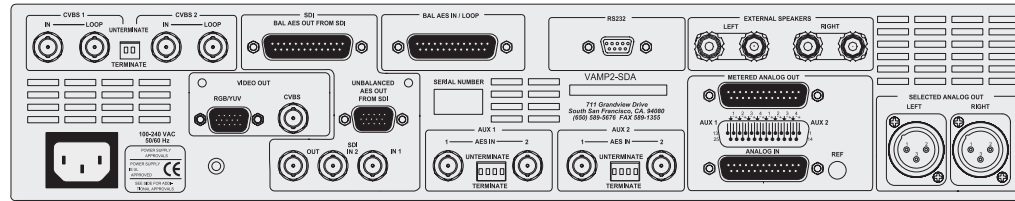

Features:

- 4" Color LCD Video Screen - Autosensing NTSC/PAL
- Self-Powered Speaker System
- 53-Segment Tri-Color LED Level Meters showing Simultaneous VU & PPM
- 2 SDI and 2 Composite Video Inputs
- Converts SDI to Analog Composite Video Output
- SDI to RGB/YUV Video Output
- Deembeds any selected Audio Group from SDI to AES/EBU Digital and Analog Outputs
- Convenient Front Panel SDI Audio Group Select Control
- Two Pairs of 2 AES/EBU or two pairs of 4 Analog Audio Inputs
- Internal or External Speaker Switch (No Amplifier Needed)
- Headphone Jack (mutes speakers)
- Low Power Consumption
- Requires only 2U of Rackspace

VAMP2-SDA offers the ability to monitor both audio and video from two selectable SDI digital and two composite analog video sources in a space-saving 2U unit. A pair of auxiliary AES inputs and eight analog audio inputs are also included for applications that don't use embedded audio.

The built-in color LCD screen allows confidence monitoring of video from either the SDI input or composite analog video inputs. Also included is a composite video monitor output from the selected SDI source for use with larger, external video monitors.

The analog audio section features four channels and level meters; any of the four channels may be selected independently and sent to the two channel speaker system, headphone output, and phase indicator. The VAMP2-SDA is capable of independent monitoring of each audio track and is a useful tool for converting and demuxing digital signals.

VAMP2-SDA is ideal for broadcast facilities needing confidence-level audio/video monitoring where operator-convenient rackspace is at a premium. Built and rigorously tested in the USA, the VAMP2-SDA is backed by a strong warranty and a "Satisfaction Guaranteed" return policy.



PANORAMAdtv
LCD VIDEO MONITORING

Video Monitoring

Level Metering

Alarm Systems

Audio Monitoring

VAMP2-SDA

SDI Video & Audio Monitoring in 2U

INPUTS

- 2 SDI (video & embedded audio) inputs (select 1) on BNC connectors
- 2 Composite video inputs with termination switches (select 1) on BNC connectors
- 4 AES/EBU digital audio inputs on BNCs with termination switches (unbalanced) and DB25 (balanced). Select 1 of 2 groups of 2.
- 8 analog audio inputs on a DB25 connector (select 1 group of 4)

OUTPUTS

- 1 reclocked SDI output of selected SDI input on a BNC connector
- 2 loop-through composite video outputs on BNC connectors
- 2 AES/EBU digital audio outputs from selected SDI group on a DB-25 connector (balanced) and HD15 connector (unbalanced)
- 4 analog outputs from either selected SDI group or selected AES/EBU digital audio group on a DB25 connector
- 2 analog audio outputs from 2 selected channels from SDI, AES/EBU digital or analog audio inputs on XLR connectors
- Left and right external speaker outputs on 5-way binding posts

System Diagram:

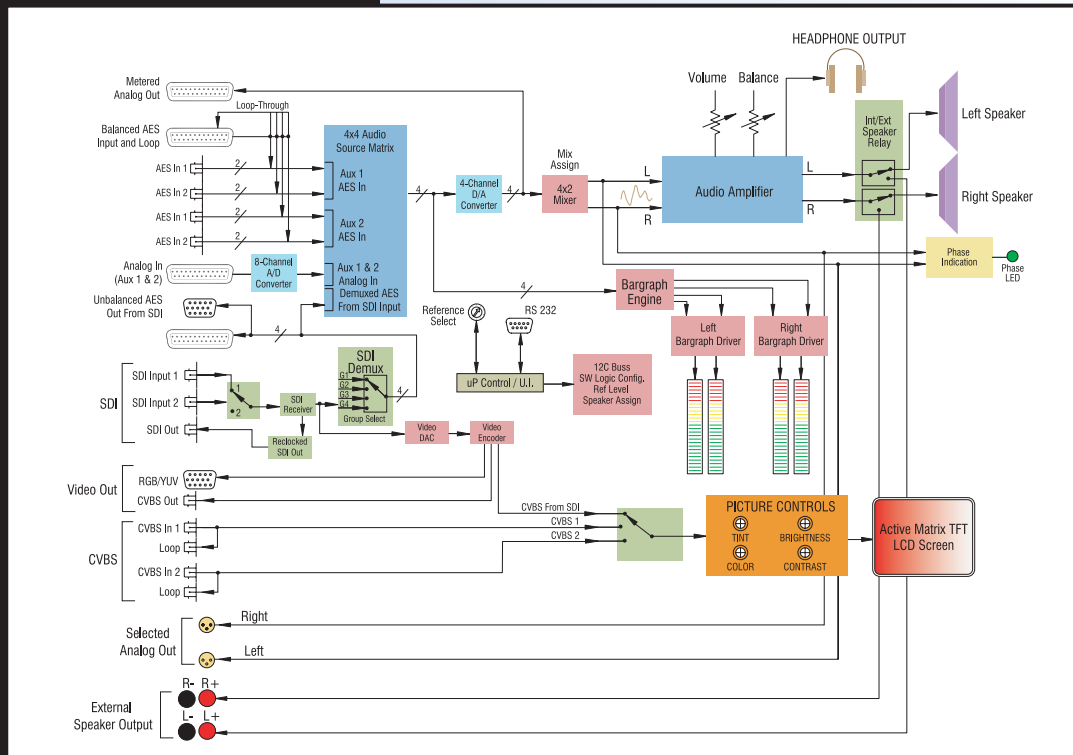

Audio Specifications:

Peak acoustic output	97 dB SPL (@ 2 ft.)
Electrical response	20Hz - 20kHz ± 1dB
Acoustic response, 1/6th octave	170 Hz - 16 kHz (±5 dB) (-10dB @ 140Hz, 20kHz)
Speaker AMP power output	20 W transient / 11 W cont RMS each side (4 ohm)
Distortion, electrical	<0.15% at any level below input threshold
Distortion, acoustic	Typically less than 1.5% at frequencies above 200 Hz; 6% or less at worst case
Hum and noise	More than 70 dB below full output

Video Specifications:

Screen size	4" diagonal
Screen type	active matrix TFT
Display modes	NTSC/PAL autosensing
Aspect ratio	4:3
LCD active area	.821 x 61.8mm
Picture controls	brightness, chroma, tint & contrast
Resolution (dots x lines)	480 x 234
Dot pitch	0.171 x 0.264mm
Color configuration	RGB stripe
Viewing angle	top=10°, bottom=30° left=45°, right=45°
Contrast ratio	150 (typ.)
Brightness	250 NITs (cd/m ²)
LCD lamp life	15,000 hours (avg.)

General Specifications:

Magnetic Shielding	<0.8 gauss any adjacent surface
Chassis type	2U, 19" rackmounting
Dimensions (HxWxD)	3.5" x 19" x 8" (89 x 483 x 203mm)
Weight	12lbs (5.5kg)
Power consumption	60W
Power supply	100 to 240VAC, 50/60Hz, universal input CE & UL approved internal power supply